

9011 PYROSHIELD[®] XH SYN GEAR LUBRICANT 6405 MONOLEC[®] R&O COMPRESSOR/TURBINE OIL

SUNBURY GENERATION LP, Shamokin Dam, Pennsylvania
Foster Wheeler Ball Mills • SIC 4911 Electric Services

Waste oil collection greatly improved Pinion shaft bearing temperatures 40° cooler

CUSTOMER TESTIMONIAL

CUSTOMER PROFILE

Sunbury Generation LP, located along the Susquehanna River in Shamokin Dam, Pennsylvania is an independent power producer which owns and operates the Sunbury Generating Station. Sunbury Generating Station produces 459 megawatts of power, 409 megawatts generated by four steam turbines fueled by coal, 50 megawatts generated by 3 combined cycle units using fuel oil.



APPLICATION

Sunbury Generation LP has 13 Foster Wheeler D7d Ball Mills used to pulverize coal for steam turbine Units #1, 2, 3 and 4.

AREA OF INTEREST

A very costly pinion gear replacement had recently been required due to an automatic lube system failure. The open gear lubricant being used was a premium, black asphaltic type lubricant. The lubricant was extremely messy to apply and work with. Automatic

lubricant spray systems required attention in order to prevent blocked lines and spray nozzles. Waste oil was very difficult to contain and remove due to its becoming very hard and tar-like in recovery chutes and pans. The product was also impacting and building up in the bull and pinion gear tooth root area, which can lead to additional wear and adds loading on pinion shaft bearings. The customer also desired to reduce the amount of product being applied.

LE SOLUTION

LE Lubrication Consultants, David Bolger and John Hayes recommended replacing the black open gear lubricant with LE 9011 PYROSHIELD[®] XH Syn-Gear Lubricant. LE 9011, a unique, extremely heavy duty, synthetic fluid developed specifically for ball/grinding mill applications which call for an EP

**LUBRICATION
ENGINEERS, Inc.**

Leaders in Lubricants



300 Bailey Ave • Fort Worth, TX • Phone: 800-537-7683 817-916-3200
FAX: 800-228-1143 817-820-0027 • www.le-inc.com

L170656
11-16-07

lubricant to be applied using automatic spray systems. 9011 contains ALMASOL, LE's exclusive wear reducing additive and a non-chlorinated diluent to ensure good low temperature mobility. It pumps easily through auto lube systems even during cold start ups. It will not harden nor solidify and does not plug spray system lines, metering valves and spray nozzles. The fluid nature promotes good housekeeping practices, allowing easy channeling and collection of waste oil. 9011 is translucent purple and non-staining.

CUSTOMER COST SAVINGS

Sunbury Generation decided to convert, as a test, two Foster Wheeler Ball Mills to 9011. As a service to the customer, David Bolger advised and participated during the conversion process which involved cleaning and tuning the spray systems and monitoring surface temperatures of the gear sets to ensure a glitch free transition. The goal being to reduce gear surface temperatures and the amount of lubricant sprayed.

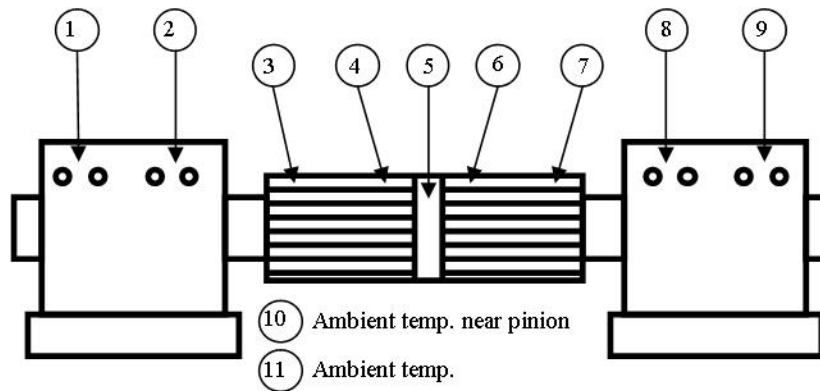

Mill#	Date	Time	Interval	1	2	3	4	5	6	7	8	9	10	11
1A-1	9/12/07	1030	15 min	149	148	172	160	155	163	160	152	152	102	85
1A-2	9/12/07	1045	10 min	181	184	186	182	178	181	191	191	192	109	86
	Dif		¼ Falk	32	36	14	22	23	18	31	39	40	7	1
1A-1	9/19/07	1430	15 min	144	140	163	154	147	157	152	144	147	98	85
1A-2	9/19/07	1445	10 min	184	184	183	181	174	176	189	189	192	115	83
	Dif		¼ Fak	40	44	20	27	27	19	37	45	45	17	-2

Note: Mill 1A-1 using LE 9011 Pyroshield XH Syn-Gear Open Gear and LE 6405 Monolec R&O (ISO 150) Compressor/Turbine Oil
 Mill 1A-2 using Petron Gear Shield open gear and Gulf Harmony (ISO 150) Lubricant

Waste oil collection is greatly improved. Waste oil is easily directed to and collected in small pans. Compacted lubricant is eliminated along with build up on shrouds.

Lubricant Specialist David Bolger also monitors, records and logs gear surface and pinion bearing temperatures monthly. A log copy is updated and maintained by the maintenance dept. for reference.

While collecting temperature data in the initial phases of the open gear lube trial, high pinion shaft bearing temperatures were noted. LE 6405 MONOLEC® R&O Compressor/Turbine Oil was recommended to reduce temperatures in this large Babbitt type bearing application. Sunbury Generation decided to install the LE 6405 in the two ball mills under test. After a short break-in period pinion shaft bearing temperatures have been dramatically reduced from approximately (181-192) to (140-152). See above chart.



Mill #1A-2 with tar based lubricant.

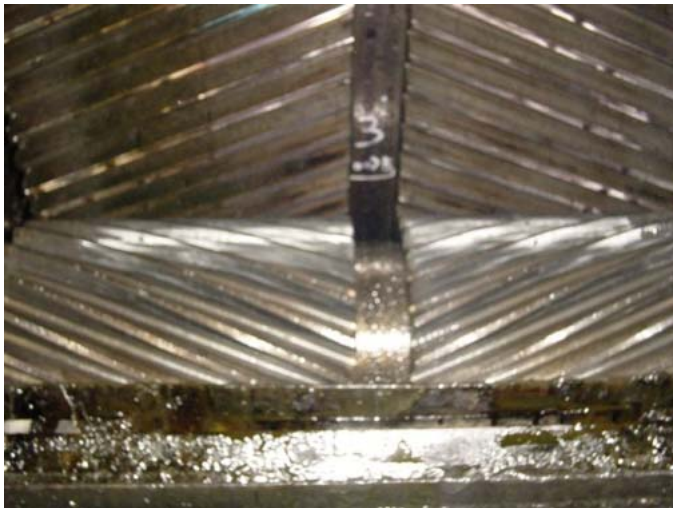

Mill 1A-1 using Pyroshield with clean gear technology

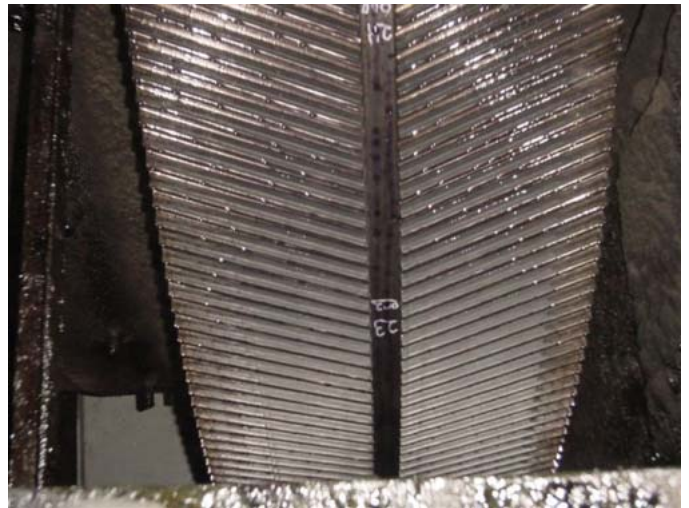

Back side of bull gear Mill #1A-1.

OTHER PRODUCTS USED

- * 6451 MONOLEC® Turbine Oil



John Hayes

Lubrication Engineers would like to thank Steve Petrich, Rick Facer and LE Lubrication Consultants John Hayes and Dave Bolger for the information provided to prepare this report.



Dave Bolger